



Attention, Risk of
Danger, Warning



High Voltage,
Risk of Electric Shock



Double / Reinforced
Insulation



NOT
Litter



CE Mark

TECHNICAL SPECIFICATION



- **Dimensions** : 35 x 102 x 117 mm, DIN rail mount
- **Sensor Type** : J,K,T,S,R type T/C, Pt100 selectable; PT100 only for THSR-1P
- **Measuring Scale** : -100..600 °C, J type T/C (Inpt=J), -100.0 .. 600.0 °C, J type T/C (Inpt=J.0)
 -100..1300 °C, K type T/C (Inpt=k), -100.0..999.9 °C, K type T/C, (Inpt=k.0)
 -100..400 °C, T type T/C (Inpt=t), -100.0 .. 400.0 °C, T type T/C (Inpt=t.0)
 0..1750 °C, S type T/C (Inpt=S) 0 .. 1750 °C, R type T/C (Inpt=r)
 -100..600 °C, Pt100, (Inpt=Pt) -100.0 .. 600.0 °C, Pt100, (Inpt=Pt.0)



- **Resolution** : ± 1 °C or ± 0.1 °C
- **Accuracy** : ± 1 % (Over full scale)
- **Control Form** : ON-OFF or P, PI, PD, PID - selectable
- **Relay Output** : 4 x Relay, 250VAC, 2A, Resistive load
- **SSR Output** : 4 x SSR, 24Vdc, 20mA / output
- **Digital Inputs** : 2 x 24Vdc
- **Communication** : 1 x RS485, MODBUS RTU
- **Line Termination** : Short circuit LT pin to RS485+ pin externally.



- **Cold. Junc. Comp.** : 0 .. 50 °C (T/C)
- **Line Comp.** : 10 Ohm max. (3 wire Pt100)
- **Supply Voltage** : 18-32Vdc
- **Power Consumption** : < 6W
- **Humidity** : < 80% (non-condensing)
- **Altitude** : < 2000 m



- **EMC** : TS EN 61000-6-2:2019, IEC 61000-6-2:2016 RLV
 TS EN 61000-6-4:2020, IEC 61000-6-4:2018 RLV



- **Safety** : TS EN 61010-1:2012 + A1:2019 + A1/AC:2019
- **Protection Class** : IP20; according to EN 60529
- **OperatingTemp.** : 0 .. 50 °C
- **Storage Temperature** : -10°C .. 60°C (no icing)
- **Weight** : < 0.5 kg
- **Torque for screwing** : Max. 0.5 N.m

WARNING: if 2 wire Pt100 is used, connect compensation lead to measuring lead:
(THSR-1P: 22-23)

<input type="checkbox"/> PWR	18...32Vdc
<input type="checkbox"/> COM	
<input type="checkbox"/> CH-1	CH Status:
<input type="checkbox"/> CH-2	on:ok
<input type="checkbox"/> -----	flash:err
<input type="checkbox"/> -----	p.flash:tune
<input type="checkbox"/> -----	f.flash:ramp
<input type="checkbox"/> DIN-1	
<input type="checkbox"/> DIN-2	
<input type="checkbox"/> RLY-1	
<input type="checkbox"/> RLY-2	
<input type="checkbox"/> RLY-3	
<input type="checkbox"/> RLY-4	
<input type="checkbox"/> SSR-1	
<input type="checkbox"/> SSR-2	
<input type="checkbox"/> SSR-3	
<input type="checkbox"/> SSR-4	

Tense THSR-2







1	+	Supply In:	
2	-	18...32Vdc	
3	-	DIn-1	DIn-1, DIn-2:
4	-	DIn-2	max. 18...32Vdc
5	-	SSR-1	
6	-	SSR-2	max. 20mA
7	-	SSR-3	18...32Vdc.
8	-	SSR-4	SSR-1...SSR-4:
9	↗	RLY-1...RLY-4:	
10	↘	Relay, max. 2A, 250Vdc, res. load	
11	↗	RLY-1	
12	↘	RLY-2	
13	↗	RLY-3	
14	↘	RLY-4	
15	↗		
16	↘		

Tense
Temperature Controller
THSR-2
www.tense.com.tr



Ch2	T/C	-	24
		+	25
		-	26
		+	27
Ch1	T/C	-	22
		+	23
		-	20
		+	21
		-	19
		+	18
RS485		-	17
		+	18
LT		-	17
		+	18

INSTALLATION, USE and WARNINGS

- 
 - This device and its packing is NOT litter and may NOT be disposed of with domestic waste. Please return this device and its packing to an appropriate recycling point at the end of its service life.
 - Please read this user manual carefully and completely before installation and use. Please take into consideration all warnings mentioned in this manual.
- 
 - **THSR-2 / THSR-1P** are suitable only for permanent DIN rail type mounting.
 - Installation and use of this device must be done by qualified, authorized and trained technical personnel only.
 - Inspect device carefully before installation. Do not install and use broken and defective devices.
- 
 - Do not disassemble device. Do not make any repair on any part of the device. There is no accessible part inside the device. Please contact to manufacturer for broken and defective devices.
 - Do not use device in environments subject to flammable, explosive and corrosive gases and/or substances.
 - This device is designed for applications only in light industrial environments. This device is not suitable for medical and residential use. This device is not suitable for use related with human health and safety. This device is not suitable for automotive, military and marine use.
- 
 - Do not allow children and unauthorized people to use this device.
 - Before installation and any technical work, disconnect the power supply and mains connections.
 - Check the power supply voltage level before power on, and make sure voltage level is in specified limits. Check quality of neutral line. Improper neutral line may give permanent damage to the device.
 - Connect an external power switch and an external fuse (1A, 250VAC) to the power supply line that are easily accessible for rapid intervention. Connect an external fuse (2A, 250VAC) for each relay output separately.
 - Use appropriate cables for power supply and mains connections. Apply safety regulations during installation.
 - Install the device in a well ventilated place. Install the device permanently into a proper panel cut-out. Fix the device with two fasteners supplied with the device. Only front panel must be accessible after installation is completed.
- 
 - Do not operate the device other then the environmental conditions given in Technical Specification.
 - Do not operate the device in environments that may cause conductive pollution.
 - Take precautions against negative environmental conditions like humidity, vibration, pollution and high/low temperature during installation.
 - Use correct compensation cables for T/C sensors. Connect T/C cable directly to the device connectors.
 - Keep device, signal cables and communication cables away from circuit breakers, power cables and devices/cables emitting electrical noise. Use shielded and twisted signal and communication cables and connect shield to earth ground on device side. Keep length of signal and communication cables less than 3m.
 - In your applications, always use separate and independent mechanical and/or electromechanical devices/apparatus to support **THSR-2 / THSR-1P** to handle emergency cases.
- 
 - Use insulated cable end-sleeves at the end of cables screwed to the device connector terminals.
 - Maximum torque for screwing; 0.5 N.m.
 - Please check www.tense.com.tr for latest device and documentation updates regularly. All updates and all information are subject to change without notice.
 - Sensor inputs and RS-485 inputs are not electrically isolated from each other. Possible ground fault may result RS-485 communication failure.

RS485 BUILD-IN LINE TERMINATION

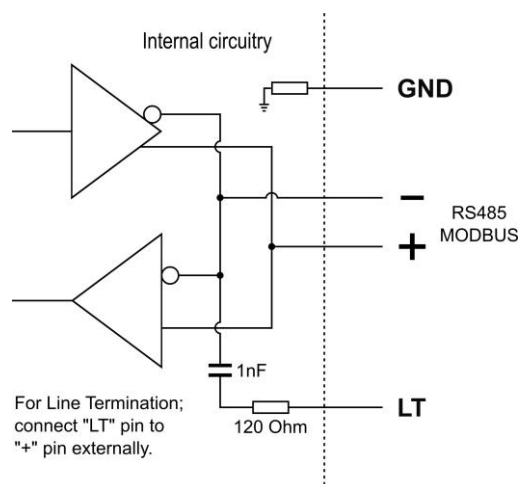

WIRING

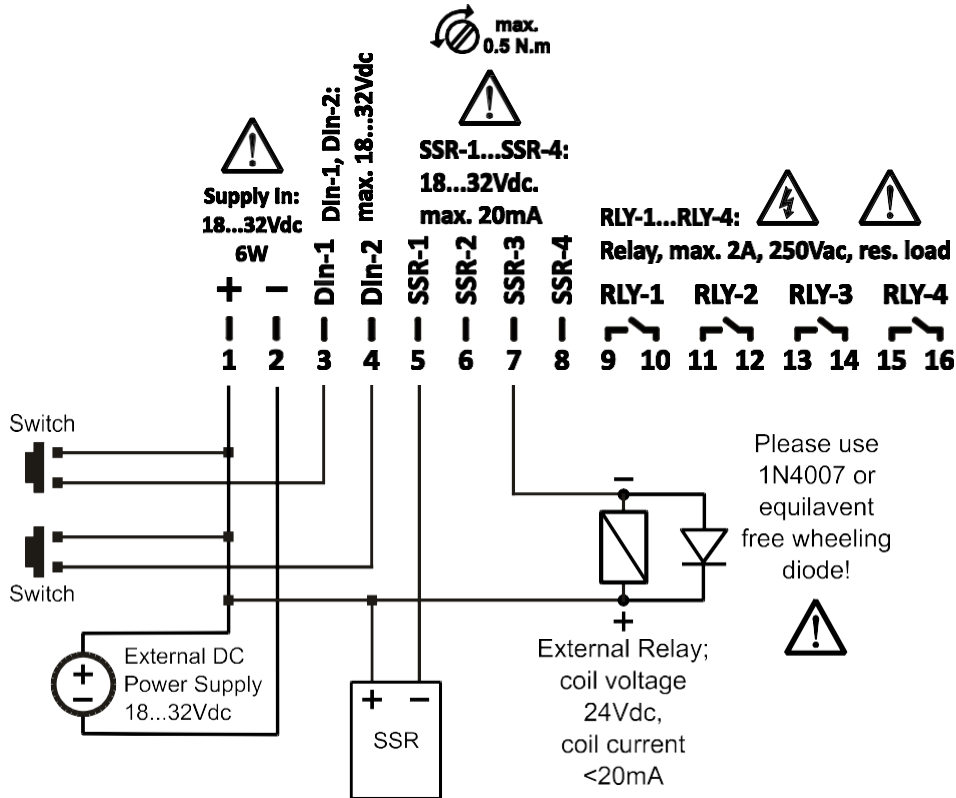

WARNING: If a relay will be driven by using an SSR output, supply voltage of device and the coil voltage of relay should be 24Vdc, and coil current should be less than or equal to 20mA. Also a free wheeling diode (1N4007 or compatible) should be connected across the coil terminals as shown at the above figure, otherwise SSR output may damage permanently.

The SSRs, that will be driven by the SSR outputs, should an input voltage compatible with device power supply. For example if device power supply is 24Vdc, then SSR inputs should support at least 24Vdc.

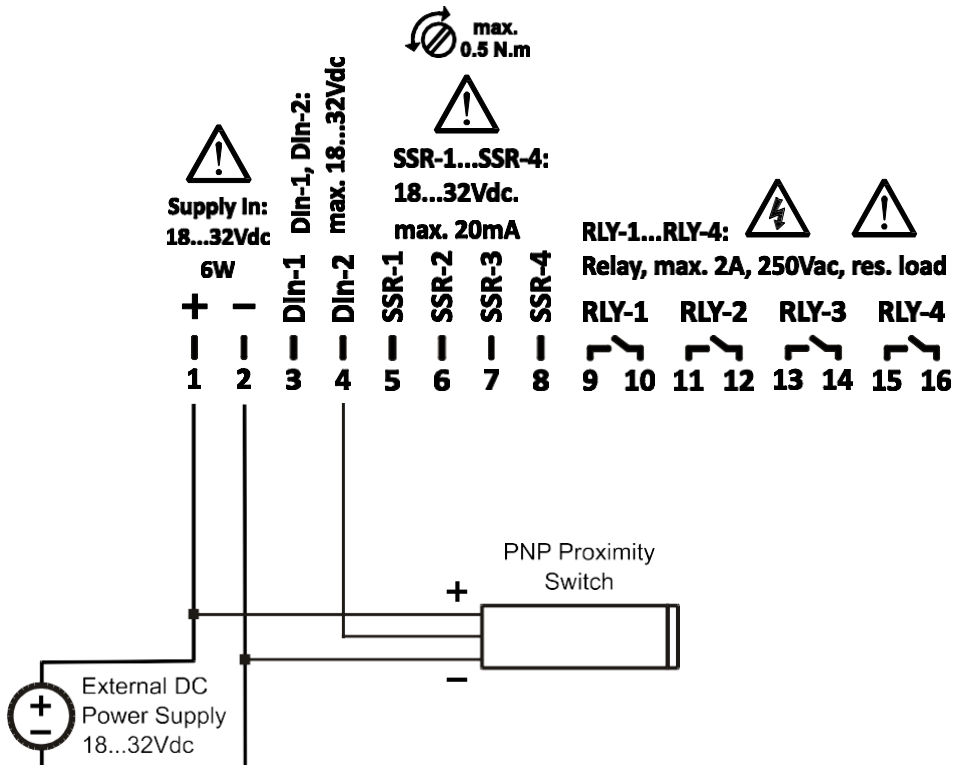

ALARM TYPES

AL.tY = Abs, -Abs; X = A.SET
 AL.tY = rel, -rel ; X = H.SET + r.ALr

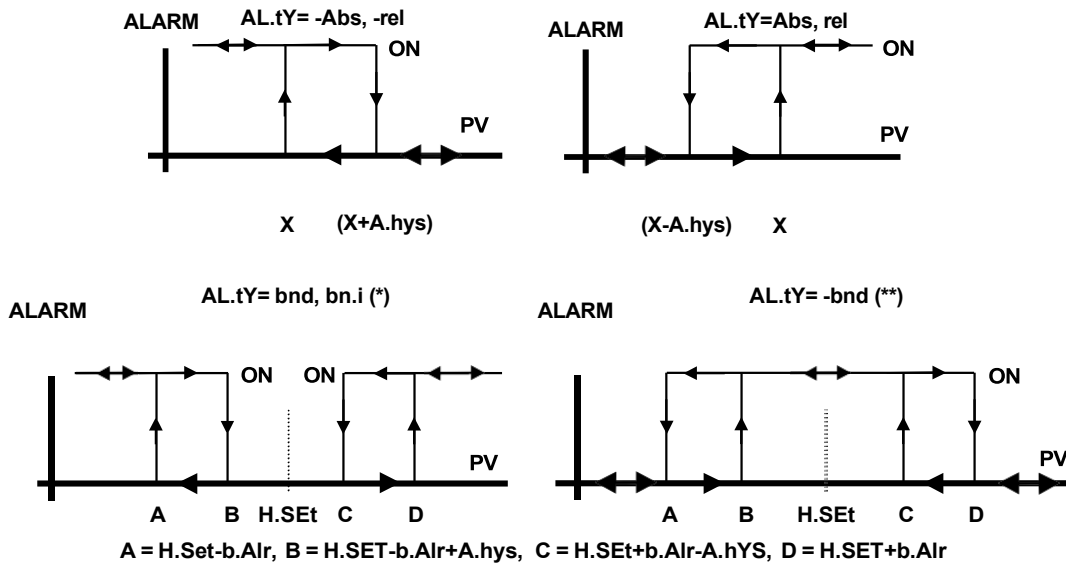

(*) AL.tY = bn.i is same as bnd except that if AL.tY = bn.i, ALARM is never ON before PV is in band.
 (**) AL.tY = -bn.i is always same as -bnd.

AL.ty = SnS.O: If sensor measurement fails; Alarm out is continuously ON.

AL.ty = SnS.F: If sensor measurement fails; Alarm out is flashing (1 second ON then 2 seconds OFF, periodically).

ON-OFF CONTROL

ON-OFF is active when "H.Hys" is other then 0

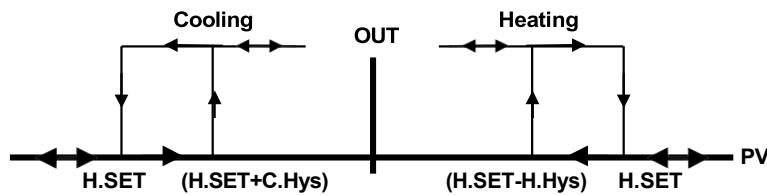

PID PARAMETERS

- **P, PI, PD, PID** is active when "H.Hys" is set to 0 (only for heating; h-C is set to "HEAT")
- **PbC:** Proportional band in °C.
- **Ct:** Control period for PID control. Prefer 4-10 sec.
- **Ti:** Integral time; Set in minutes. Determines how fast controller reacts to compensate the offset between SET point and the process value. If set to 0, integral part is OFF. If set too low, process value may oscillate.
- **Td:** Derivative time; Set in minutes. If set to 0, derivative part is OFF. Determines how sensitive the controller is to changes of the offset between SET point and the process value. If set too high, process value may oscillate or overshoot.

CH1 ... CH4 LED STATUS INFORMATION



CHx LED;

Continuously ON: Measurement is valid,

Slow Flash: Measurement is NOT valid; sensor failure or out of measurement scale,

Fast Flash: "Soft-start" is active,

Pulse Flash: "Auto-tune" is active.

CLEANING

Do not use any solvents (alcohol, thinners, benzene, acid, etc.) or corrosive substances to clean the device. Use only a dry and clean non-abrasive cloth. Before cleaning, disconnect the power supply and mains connections.

MODBUS Connection and Addressing Information

for

THSR Series Devices

May, 2026

Document Revision: 1.3

www.tense.com.tr

All trademarks, service marks, trade names, product names, corporate names, company names, logos, and etc. appearing on this document are the property of their respective owners, and mentioned in this document for reference and explanation purposes only.

All information subject to change without notice.

Content

1.Introduction	4
2.Supported Messages	5
3."0x" Coils (1 bit each)	6
3.1 NetIn Coils.....	6
3.2 EnableRelay Coils.....	6
3.3 EnableSSR Coils.....	6
3.4 "0x"; MODBUS Address Table of Coils	6
4."1x" Discrete Inputs (1 bit each).....	8
4.1 DIn Inputs	8
4.2 CntOuts.....	8
4.3 AlrOuts	8
4.4 RlyOuts.....	8
4.5 SSROuts	8
4.6 CodeCRCErr.....	8
4.7 CalibCRCErr.....	8
4.8 DataCRCErr.....	8
4.9 OutCRCErr	9
4.10 ModbusCRCErr	9
4.11 SET12CRCErr	9
4.12 CntCRCErr.....	9
4.13 AlrCRCErr	9
4.14 "1x"; MODBUS Address Table of Discrete Inputs	9
5."3x" Input Registers (Read Only; 16 bits each)	11
5.1 Chx_MeasurementOutOfRange	11
5.2 Chx_Measured_C	11
5.3 Chx_Current_H_Set.....	11
5.4 Chx_RampONFlag	11
5.5 Chx_RampSET_C	11
5.6 Chx_AutoTuneFlag	11
5.7 Chx_AutoTune_State.....	11
5.8 Chx_AutoTuneElapsedTimeinSecs	12
5.9 Digital_Inputs	12
5.10 Control_Outputs.....	12
5.11 Alarm_Outputs.....	12
5.12 Relay_Outputs.....	12
5.13 SSR_Outputs.....	12
5.14 System_Status	13
5.15 Device_ID.....	13
5.16 Device_Revision	13
5.17 "3x"; MODBUS Address Table of Input Registers	13
6."4x" Holding Registers (Read/Write; 16 bits each)	16
6.1 SlaveAddress	16
6.2 BaudRate	16
6.3 Parity.....	16
6.4 ResponseToMasterDelay	16
6.5 OutTypeForRLYx.....	16
6.6 OutTypeForSSRx	16

6.7 Chx_SET1	16
6.8 Chx_SET2	16
6.9 Chx_SensorType.....	17
6.10 Chx_H_Hys.....	17
6.11 Chx_Pbc.....	17
6.12 Chx_ti.....	17
6.13 Chx_td.....	17
6.14 Chx_OverShoot.....	17
6.15 Chx_Ramp_C_t.....	17
6.16 Chx_SensorOffset	18
6.17 Chx_P_Err.....	18
6.18 Chx_C_dLY	18
6.19 Chx_SET_2_InputSelect.....	18
6.20 Chx_AlInputSelectIndex.....	18
6.21 Chx_AbsoluteAlarmSET	18
6.22 Chx_AlarmHYS.....	18
6.23 Chx_AlarmType.....	19
6.24 Chx_AlarmRelALR	19
6.25 NetInData	19
6.26 EnableRelaysData	19
6.27 EnableSSRsData	19
6.28 "4x"; MODBUS Address Table of Holding Registers	20
7.Document Updates Summary	27



1. Introduction

THSR series devices are rail-mounted, "auto-tune" PID temperature controllers with one or more sensor inputs, with each sensor type selectable. With the relay and SSR outputs they have, they can continue the temperature control process independently, without the need for any network connection, after the parameters are set.

THSR series devices have 1 or 2 temperature sensor inputs, depending on the device type. A separate temperature control block operates for each sensor input. Control outputs of temperature control blocks are CntOutx contacts.

THSR series devices have 4 alarm control blocks. An alarm block can be associated with any sensor. Control outputs of alarm control blocks are AlrOutx contacts.

THSR series devices have 2 physical digital inputs. These inputs can be accessed via DI_nx contacts.

THSR series devices may connect an RS-485 MODBUS network as a slave.

THSR series devices support only MODBUS RTU mode of communication.

You can use TENSEModuleMaster software (free of charge) to pre program (adjust the parameters, set the configuration) THSR series devices. You can download TENSEModuleMaster software from www.tense.com.tr.

2. Supported Messages

- 01 (0x01) Read Coils
- 02 (0x02) Read Discrete Inputs
- 03 (0x03) Read Holding Registers
- 04 (0x04) Read Input Registers
- 05 (0x05) Write Single Coil
- 06 (0x06) Write Single Register
- 15 (0x0F) Write Multiple Coils
- 16 (0x10) Write Multiple registers

3. "0x" Coils (1 bit each)

3.1 NetIn Coils

NetIn coils are virtual coils that can be read and written via MODBUS network. NetIn coils may be routed (virtually connected) to Relay and SSR outputs, hence Relay and SSR outputs may be used as general purpose outputs. NetIn coils are set to 0 after power on.

3.2 EnableRelay Coils

EnableRelay coils are used to enable/disable relay outputs. If EnableRelayx is 1, RlyOutx is enabled. If EnableRelayx is 0, RlyOutx is disabled. EnableRelay coils are set to 1 after power on.

3.3 EnableSSR Coils

EnableSSR coils are used to enable/disable SSR outputs. If EnableSSRx is 1, SSROutx is enabled. If EnableSSRx is 0, SSROutx is disabled. EnableSSR coils are set to 1 after power on.

3.4 "0x"; MODBUS Address Table of Coils

Contact Name	Address	Explanation	Access
NetIn1	0	NetIn Coil 1	Read / Write
NetIn2	1	NetIn Coil 2	Read / Write
NetIn3	2	NetIn Coil 3	Read / Write
NetIn4	3	NetIn Coil 4	Read / Write
NetIn5	4	NetIn Coil 5	Read / Write
NetIn6	5	NetIn Coil 6	Read / Write
NetIn7	6	NetIn Coil 7	Read / Write
NetIn8	7	NetIn Coil 8	Read / Write
8 - 15 Reserved, do not write			
EnableRelay1	16	1:Enabled, 0:Disabled; for RlyOut1	Read / Write
EnableRelay2	17	1:Enabled, 0:Disabled; for RlyOut2	Read / Write
EnableRelay3	18	1:Enabled, 0:Disabled; for RlyOut3	Read / Write
EnableRelay4	19	1:Enabled, 0:Disabled; for RlyOut4	Read / Write
20 - 31 Reserved, do not write			
EnableSSR1	32	1:Enabled, 0:Disabled; for SSROut1	Read / Write

EnableSSR2	33	1:Enabled, 0:Disabled; for SSROut2	Read / Write
EnableSSR3	34	1:Enabled, 0:Disabled; for SSROut3	Read / Write
EnableSSR4	35	1:Enabled, 0:Disabled; for SSROut4	Read / Write
36 - 47 Reserved, do not write			

4. "1x" Discrete Inputs (1 bit each)

4.1 DIn Inputs

DIn inputs hold the state of hardware inputs of device. DIn inputs may be used as general purpose digital inputs and may be accessed via MODBUS network. Also DIn inputs may be used to select SET1 or SET2 as the set point for temperature control of a channel.

4.2 CntOuts

CntOuts are the state of control outputs of temperature control blocks. If temperature control block is set to PID mode, corresponding CntOut is always 0. If temperature control block is set to ON/OFF mode, corresponding CntOut is 0 or 1. CntOut2, CntOut3 and CntOut4 may always be 0 if device has only 1 or 2 sensor input(s).

4.3 AlrOuts

AlrOuts are the state of alarm control blocks.

4.4 RlyOuts

RlyOuts are the state of physical relay outputs of device.

4.5 SSROuts

SSROuts are the state of physical SSR outputs of device.

4.6 CodeCRCErr

CodeCRCErr is set to 1 if the region of the non volatile memory where the executing code is stored, is detected to be corrupted. Normally CodeCRCErr is 0. If CodeCRCErr is 1, then device does not operate and flashes power LED only, even MODBUS messaging is stopped.

4.7 CalibCRCErr

CalibCRCErr is set to 1 if the region of the non volatile memory where the calibration data is stored, is detected to be corrupted. Normally CalibCRCErr is 0. If CalibCRCErr is 1, then device does not operate and flashes power LED only, MODBUS messaging continues.

4.8 DataCRCErr

If any one or more of error flags, OutCRCErr, ModbusCRCErr, SET12CRCErr, CntCRCErr, AlrCRCErr is 1 then DataCRCErr is also 1. MODBUS messaging continues.

4.9 OutCRCErr

OutCRCErr is set to 1 if the region of the non volatile memory where the output (relay/SSR) configuration of device is stored, is detected to be corrupted. Normally OutCRCErr is 0. If OutCRCErr is 1, then device does not operate and flashes power LED only, MODBUS messaging continues.

4.10 ModbusCRCErr

ModbusCRCErr is set to 1 if the region of the non volatile memory where the Modbus configuration of device is stored, is detected to be corrupted. Normally ModbusCRCErr is 0. If ModbusCRCErr is 1, then device does not operate and flashes power LED only, MODBUS messaging continues with a default configuration.

4.11 SET12CRCErr

SET12CRCErr is set to 1 if the region of the non volatile memory where the SET1 & SET2 parameters of the control blocks of device are stored, is detected to be corrupted. Normally SET12CRCErr is 0. If SET12CRCErr is 1, then device does not operate and flashes power LED only, MODBUS messaging continues.

4.12 CntCRCErr

CntCRCErr is set to 1 if the region of the non volatile memory where the parameters of the control blocks of device are stored, is detected to be corrupted. Normally CntCRCErr is 0. If CntCRCErr is 1, then device does not operate and flashes power LED only, MODBUS messaging continues.

4.13 AlrCRCErr

AlrCRCErr is set to 1 if the region of the non volatile memory where the parameters of the alarm blocks of device are stored, is detected to be corrupted. Normally AlrCRCErr is 0. If AlrCRCErr is 1, then device does not operate and flashes power LED only, MODBUS messaging continues.

4.14 "1x"; MODBUS Address Table of Discrete Inputs

Contact Name	Address	Explanation	Access
DIn1	0	Physical Digital Input 1	Read only
DIn2	1	Physical Digital Input 2	Read only
2 - 15 Reserved			
CntOut1	16	Control Output 1	Read only
CntOut2	17	Control Output 2	Read only
CntOut3	18	Control Output 3	Read only

CntOut4	19	Control Output 4	Read only
20 - 31 Reserved			
AlrOut1	32	Alarm Output 1	Read only
AlrOut2	33	Alarm Output 2	Read only
AlrOut3	34	Alarm Output 3	Read only
AlrOut4	35	Alarm Output 4	Read only
36 - 47 Reserved			
RlyOut1	48	Relay Output 1	Read only
RlyOut2	49	Relay Output 2	Read only
RlyOut3	50	Relay Output 3	Read only
RlyOut4	51	Relay Output 4	Read only
52 - 63 Reserved			
SSROut1	64	SSR Output 1	Read only
SSROut2	65	SSR Output 2	Read only
SSROut3	66	SSR Output 3	Read only
SSROut4	67	SSR Output 4	Read only
68 - 79 Reserved			
CodeCRCErr	80	Code CRC Error	Read only
CalibCRCErr	81	Calibration CRC Error	Read only
DataCRCErr	82	Data CRC Error	Read only
OutCRCErr	83	Output Parameters CRC Error	Read only
ModbusCRCErr	84	MODBUS Parameters CRC Error	Read only
SET12CRCErr	85	SET1 & SET2 CRC Error	Read only
CntCRCErr	86	Control Parameters CRC Error	Read only
AlrCRCErr	87	Alarm Parameters CRC Error	Read only
88 - 95 Reserved			

5. "3x" Input Registers (Read Only; 16 bits each)

5.1 Chx_MeasurementOutOfRange

Chx_MeasurementOutOfRange is 1 in case of a sensor failure or measurement is out of range. If Chx_MeasurementOutOfRange is 1, Chx_Measured_C is set to 0.

Chx_MeasurementOutOfRange is 0 if sensor measurement is successful. Chx_Measured_C is valid and correct only if Chx_MeasurementOutOfRange is 0.

5.2 Chx_Measured_C

Chx_Measured_C is the measured temperature in centigrade (°C). If any sensor type ending with ".0" is selected, Chx_Measured_C is x10; for example if sensor type is "PT100.0" and if temperature is 102.5°C, then register content is 1025.

Chx_Measured_C is valid and correct only if MeasurementOutOfRange is 0.

5.3 Chx_Current_H_Set

Chx_Current_H_Set is the current SET value in centigrade (°C). If any sensor type ending with ".0" is selected, Chx_Current_H_Set is x10; for example if SET is 102.5, then register content is 1025.

5.4 Chx_RampONFlag

Chx_RampONFlag is 1 if "soft start" or ramping is active after power on. Chx_RampONFlag becomes 0 automatically, after ramping is completed.

5.5 Chx_RampSET_C

Chx_RampSET_C is the current SET value calculated by the ramping function. Chx_RampSET_C is valid and correct only if Chx_RampONFlag is 1.

5.6 Chx_AutoTuneFlag

Chx_AutoTuneFlag is 1 if "auto-tune" function for the relevant channel is active. Chx_AutoTuneFlag becomes 0 after "auto-tune" function is completed.

5.7 Chx_AutoTune_State

Chx_AutoTune_State is the state of "auto-tune" function. It may be helpful for monitoring long "auto-tune" duration. Its content is only meaningful only when Chx_AutoTuneFlag is 1.

5.8 Chx_AutoTuneElapsedTimeinSecs

Chx_AutoTuneElapsedTimeinSecs is the duration in seconds, passed since "auto-tune" function has started. It may be helpful for monitoring long "auto-tune" duration. Its content is only meaningful only when Chx_AutoTuneFlag is 1.

5.9 Digital_Inputs

Alternative method to access DInx contacts.

DIn1 = Digital_Inputs.bit0

DIn2 = Digital_Inputs.bit1.

5.10 Control_Outputs

Alternative method to access CntOutx contacts.

CntOut1 = Control_Outputs.bit0

CntOut2 = Control_Outputs.bit1

CntOut3 = Control_Outputs.bit2

CntOut4 = Control_Outputs.bit3

5.11 Alarm_Outputs

Alternative method to access AlrOutx contacts.

AlrOut1 = Alarm_Outputs.bit0

AlrOut2 = Alarm_Outputs.bit1

AlrOut3 = Alarm_Outputs.bit2

AlrOut4 = Alarm_Outputs.bit3

5.12 Relay_Outputs

Alternative method to access RlyOutx contacts.

RlyOut1 = Relay_Outputs.bit0

RlyOut2 = Relay_Outputs.bit1

RlyOut3 = Relay_Outputs.bit2

RlyOut4 = Relay_Outputs.bit3

5.13 SSR_Outputs

Alternative method to access SSROutx contacts.

SSROut1 = SSR_Outputs.bit0

SSROut2 = SSR_Outputs.bit1

SSROut3 = SSR_Outputs.bit2

SSROut4 = SSR_Outputs.bit3

5.14 System_Status

Alternative method to access system contacts.

CodeCRCErr = System_Status.bit0

CalibCRCErr = System_Status.bit1

DataCRCErr = System_Status.bit2

OutCRCErr = System_Status.bit3

ModbusCRCErr = System_Status.bit4

SET12CRCErr = System_Status.bit5

CntCRCErr = System_Status.bit6

AlrCRCErr = System_Status.bit7

5.15 Device_ID

Each device type has a distinct device id. Device ids of devices are listed at the table below.

5.16 Device_Revision

Device firmware revision is a 3 digit number. For example, device revision = 124 means; 1.2.4.

Digit 1 is major revision, digit 2 is minor revision, digit 4 is an update.

5.17 "3x"; MODBUS Address Table of Input Registers

Register Name	Address	Explanation	Access
Ch1_MeasurementOutOfRange	0	Refer to text - Uint16	Read only
Ch1_Measured_C	1	Refer to text - Sint16	Read only
Ch1_Current_H_Set	2	Refer to text - Sint16	Read only
Ch1_RampONFlag	3	Refer to text - Uint16	Read only
Ch1_RampSET_C	4	Refer to text - Sint16	Read only
Ch1_AutoTuneFlag	5	Refer to text- Uint16	Read only
Ch1_AutoTune_State	6	Refer to text- Uint16	Read only
Ch1_AutoTuneElapsedTimeinSecs	7	Refer to text- Uint16	Read only
8 - 255; not defined			

Ch2_MeasurementOutOfRange	256	*(1) Refer to text - Uint16	Read only
Ch2_Measured_C	257	*(1) Refer to text - Sint16	Read only
Ch2_Current_H_Set	258	*(1) Refer to text - Sint16	Read only
Ch2_RampONFlag	259	*(1) Refer to text - Uint16	Read only
Ch2_RampSET_C	260	*(1) Refer to text - Sint16	Read only
Ch2_AutoTuneFlag	261	*(1) Refer to text- Uint16	Read only
Ch2_AutoTune_State	262	*(1) Refer to text- Uint16	Read only
Ch2_AutoTuneElapsedTimeinSecs	263	*(1) Refer to text- Uint16	Read only
264 - 511; not defined			
Ch3_MeasurementOutOfRange	512	*(2) Refer to text - Uint16	Read only
Ch3_Measured_C	513	*(2) Refer to text - Sint16	Read only
Ch3_Current_H_Set	514	*(2) Refer to text - Sint16	Read only
Ch3_RampONFlag	515	*(2) Refer to text - Uint16	Read only
Ch3_RampSET_C	516	*(2) Refer to text - Sint16	Read only
Ch3_AutoTuneFlag	517	*(2) Refer to text- Uint16	Read only
Ch3_AutoTune_State	518	*(2) Refer to text- Uint16	Read only
Ch3_AutoTuneElapsedTimeinSecs	519	*(2) Refer to text- Uint16	Read only
520 - 767; not defined			
Ch4_MeasurementOutOfRange	768	*(2) Refer to text - Uint16	Read only
Ch4_Measured_C	769	*(2) Refer to text - Sint16	Read only
Ch4_Current_H_Set	770	*(2) Refer to text - Sint16	Read only
Ch4_RampONFlag	771	*(2) Refer to text - Uint16	Read only
Ch4_RampSET_C	772	*(2) Refer to text - Sint16	Read only
Ch4_AutoTuneFlag	773	*(2) Refer to text- Uint16	Read only
Ch4_AutoTune_State	774	*(2) Refer to text- Uint16	Read only
Ch4_AutoTuneElapsedTimeinSecs	775	** (2) Refer to text- Uint16	Read only
776 - 1023; not defined			
Digital_Inputs	1024	Refer to text	Read only
Control_Outputs	1025	Refer to text	Read only
Alarm_Outputs	1026	Refer to text	Read only
Relay_Outputs	1027	Refer to text	Read only
SSR_Outputs	1028	Refer to text	Read only
System_Status	1029	Refer to text	Read only
1030 - 65279; not defined			

Device_ID	65280	1 : THSR-1P 2 : THSR-2	Read only
Device_Revision	65281	Refer to Text	Read only

(1) These register accessible only for the devices having 2 or more sensor inputs.

(2) These register accessible only for the devices having 3 or more sensor inputs.

Uint16: unsigned integer 16bits; 0 ... 65535

Sint16: signed integer 16bits; -32768 ... +32767

6. "4x" Holding Registers (Read/Write; 16 bits each)

6.1 SlaveAddress

MODBUS slave address of device.

6.2 BaudRate

Communication speed.

6.3 Parity

Even/Odd/No parity selection with Stop bit.

6.4 ResponseToMasterDelay

Extra delay for the response from slave to master. SET to 0 for fastest response. May be helpful for masters with non real time operating systems.

6.5 OutTypeForRLYx

Output selection for relay outputs. One of the virtual coils listed below may be routed to the selected relay.

6.6 OutTypeForSSRx

Output selection for SSR outputs. One of the virtual coils listed below may be routed to the selected SSR.

6.7 Chx_SET1

SET1 parameter value in centigrade (°C) for a temperature control channel. SET1 is the main SET point. SET1 is used in alarm control blocks and for "auto-tune" calculation. If any sensor type ending with ".0" is selected, Chx_SET1 is x10; for example if SET1 is 102.5, then Chx_SET1 register content is 1025.

6.8 Chx_SET2

SET2 parameter value in centigrade (°C) for a temperature control channel. SET2 is the auxiliary SET point. If any sensor type ending with ".0" is selected, Chx_SET2 is x10; for example if SET2 is 102.5, then Chx_SET2 register content is 1025.

SET2 is optional. Normally SET1 is the main SET point. But if SET2 is associated with a digital input (DInx), SET2 is accepted as the SET point instead of SET1 when the associated DInx input is 1 (ON). This feature may be helpful, for example, during implementing a power saving function.

6.9 Chx_SensorType

Sensor selection for Chx. Please refer to table below.

6.10 Chx_H_Hys

Heating / Cooling function selection. If cooling function is selected control is always ON-OFF form. If heating function is selected and Chx_H_Hys is not equal to 0 then control form is ON-OFF. If heating function is selected and Chx_H_Hys is equal to 0 then control form is P/PI/PD or PID.

If any sensor type ending with ".0" is selected, Chx_H_Hys is x10; for example if Chx_H_Hys is 20.5, then Chx_H_Hys register content is 205.

6.11 Chx_Pbc

If heating function is selected and Chx_H_Hys is equal to 0 then control form is P/PI/PD or PID and Chx_Pbc is the proportional band in °C.

6.12 Chx_ti

If heating function is selected and Chx_H_Hys is equal to 0 then control form is P/PI/PD or PID and Chx_ti is the integral time in seconds. If Chx_ti is 0 then control form is P or PD.

6.13 Chx_td

If heating function is selected and Chx_H_Hys is equal to 0 then control form is P/PI/PD or PID and Chx_td is the derivative time in seconds. If Chx_td is 0 then control form is P or PI.

6.14 Chx_OverShoot

If heating function is selected and Chx_H_Hys is equal to 0 then control form is P/PI/PD or PID. If PID is selected Chx_OverShoot is active.

Normally, PID control has a default overshoot elimination method even when Chx_OverShoot is set to OFF. But selecting Chx_OverShoot to a value other than OFF makes PID control be more aggressive to eliminate overshoot.

First try Chx_OverShoot set to OFF. Then if you need more aggressive overshoot elimination select first 10.0, then, 5.0, 3.0, 1.0 and lastly 0.2. 10.0 means overshoot elimination is more aggressive if measured temperature is over 10.0 °C or tends to be more than 10.0 °C, and so on. 0.2 is more aggressive than 10.0.

In some cases, more aggressive selections may cause instability, so some try and error phase may be needed.

6.15 Chx_Ramp_C_t

Chx_Ramp_C_t is the soft-start parameter. If Chx_Ramp_C_t is not 0, soft-start function is started

after power on. The current SET value is increased or decreased by Chx_Ramp_C_t (°C / minute) per minute to reach to final SET point.

The soft-start function both available for heating and cooling functions.

6.16 Chx_SensorOffset

Chx_SensorOffset value is added to sensor measurement after each measurement cycle. This parameter may be helpful for final or user calibration of a measurement.

If any sensor type ending with ".0" is selected, Chx_SensorOffset is x10; for example if Chx_SensorOffset is 2.5, then Chx_SensorOffset content is 25.

6.17 Chx_P_Err

In case of a sensor failure or measurement is out of range, control output may cycled as ON and OFF to provide a predefined amount of heat energy to the system. ON/OFF period is Chx_C_t. The ON duration is determined by Chx_P_Err. This is a percentage value; for example if Chx_C_t is 4 seconds and if Chx_P_Err is 20%, then ON duration is $4\text{sec} * 20\% = 0.8$ seconds, hence OFF duration is $4 - 0.8 = 3.2$ seconds. If Chx_P_Err is 0, then control output is always OFF.

6.18 Chx_C_dLY

Chx_C_dLY is active only for cooling function. Chx_C_dLY is the compressor protection delay. After the control output is OFF, it is waited for at least Chx_C_dLY (seconds) before it turns ON again.

6.19 Chx_SET_2_InputSelect

If Chx_SET_2_InputSelect is selected as 0, then SET2 is disabled, SET1 is always active. If Chx_SET_2_InputSelect is selected as 1, SET2 becomes active when DIn1 is ON. If Chx_SET_2_InputSelect is selected as 2, SET2 becomes active when DIn2 is ON.

This feature may be used for implementing power saving function.

6.20 Chx_AlInputSelectIndex

Chx_AlInputSelectIndex holds which sensor channel is associated to appropriate alarm control channel.

6.21 Chx_AbsoluteAlarmSET

Chx_AbsoluteAlarmSET holds the alarm SET value if alarm type is selected as "absolute".

6.22 Chx_AlarmHYS

Chx_AlarmHYS holds the alarm hysteresis value.

If any sensor type ending with ".0" is selected for the associated sensor channel, Chx_AlarmHYS is x10; for example if Chx_AlarmHYS is 2.5, then Chx_AlarmHYS content is 25.

6.23 Chx_AlarmType

Chx_AlarmType holds the alarm type for the appropriate alarm control channel.
Refer to alarm type operation for more detail.

6.24 Chx_AlarmRelALR

Chx_AlarmRelALR holds the relative alarm hysteresis value.
Refer to alarm type operation for more detail.

6.25 NetInData

Alternative method to access NetInx contacts.

NetIn1 = NetInData.bit0

NetIn2 = NetInData.bit1

NetIn3 = NetInData.bit2

NetIn4 = NetInData.bit3

NetIn5 = NetInData.bit4

NetIn6 = NetInData.bit5

NetIn7 = NetInData.bit6

NetIn8 = NetInData.bit7

Send "0" for undefined bits (bit8-bit15).

6.26 EnableRelaysData

Alternative method to access EnableRelayx contacts.

EnableRelay1 = EnableRelaysData.bit0

EnableRelay2 = EnableRelaysData.bit1

EnableRelay3 = EnableRelaysData.bit2

EnableRelay4 = EnableRelaysData.bit3

Send "0" for undefined bits (bit5-bit15).

6.27 EnableSSRsData

Alternative method to access EnableSSRx contacts.

EnableSSR1 = EnableSSRsData.bit0

EnableSSR2 = EnableSSRsData.bit1

EnableSSR3 = EnableSSRsData.bit2

EnableSSR4 = EnableSSRsData.bit3

Send "0" for undefined bits (bit5-bit15).

6.28 "4x"; MODBUS Address Table of Holding Registers

Register Name	Address	Explanation	Default	Access
SlaveAddress	0	1 ... 247	11	Read / Write
BaudRate	1	0: 9600 1: 19200 2: 38400	1	Read / Write
Parity	2	0: Even Parity, 1 Stop Bit 1: Odd parity, 1 Stop Bit 2: No parity, 1 Stop Bit 3: No parity, 2 Stop Bit	0	Read / Write
ResponseToMasterDelay	3	0 ... 250 milliseconds	0	Read / Write
Reserved	4	Do not write	0xFFFF	Read / Write
Reserved	5	Do not write	0xFFFF	Read / Write
6 - 255; not defined				
OutTypeForRLY1	256	0: Not Assigned 1: CntOut1 2: CntOut2 3: CntOut3 4: CntOut4 5...8: Reserved 9: AlrOut1 10: AlrOut2 11: AlrOut3 12: AlrOut4 13...24: Reserved 25: NetIn1 26: NetIn2 27: NetIn3 28: NetIn4 29: NetIn5 30: NetIn6 31: NetIn7 32: NetIn8 33...40: Reserved	1	Read / Write
OutTypeForRLY2	257	same as OutTypeForRLY1 list	9	Read / Write
OutTypeForRLY3	258	same as OutTypeForRLY1 list	10	Read / Write

OutTypeForRLY4	259	same as OutTypeForRLY1 list	0	Read / Write
OutTypeForSSR1	260	same as OutTypeForRLY1 list	0	Read / Write
OutTypeForSSR2	261	same as OutTypeForRLY1 list	0	Read / Write
OutTypeForSSR3	262	same as OutTypeForRLY1 list	0	Read / Write
OutTypeForSSR4	263	same as OutTypeForRLY1 list	0	Read / Write
264 - 511; not defined				
Ch1_SET1	512	-100 .. 600 °C, J T/C, -100 .. 1300 °C, K T/C, -100 .. 400 °C, T T/C, 0 .. 1750 °C, S T/C, 0 .. 1750 °C, R T/C, -100 .. 600 °C, Pt100, -100.0 .. 600.0 °C, Pt100.0, -100.0 .. 600.0 °C, J.0 T/C, -100.0 .. 1300.0 °C, K.0 T/C, -100.0 .. 400.0 °C, T.0 T/C	100	Read / Write
Ch1_SET2	513	-100 .. 600 °C, J T/C, -100 .. 1300 °C, K T/C, -100 .. 400 °C, T T/C, 0 .. 1750 °C, S T/C, 0 .. 1750 °C, R T/C, -100 .. 600 °C, Pt100, -100.0 .. 600.0 °C, Pt100.0, -100.0 .. 600.0 °C, J.0 T/C, -100.0 .. 1300.0 °C, K.0 T/C, -100.0 .. 400.0 °C, T.0 T/C	70	Read / Write
514 - 767; not defined				
Ch2_SET1	768	*(1) SET1 for channel 2 Same list as Ch1	100	Read / Write
Ch2_SET2	769	*(1) SET2 for channel 2 Same list as Ch1	70	Read / Write
770 - 1023; not defined				
Ch3_SET1	1024	*(2) SET1 for channel 3 Same list as Ch1	100	Read / Write
Ch3_SET2	1025	*(2) SET2 for channel 3 Same list as Ch1	70	Read / Write
1026 - 1279; not defined				
Ch4_SET1	1280	*(2) SET1 for channel 4 Same list as Ch1	100	Read / Write

Ch5_SET2	1281	*(2) SET2 for channel 4 Same list as Ch1	70	Read / Write
1282 - 1535; not defined				
Ch1_SensorType	1536	0: J type T/C, 1: K type T/C, 2: T type T/C, 3: S type T/C, 4: R type T/C, 5: Pt100 *(3, 4), 6: Pt100.0 *(3, 4), 7: J.0 type T/C *(3), 8: K.0 type T/C, *(3) 9: T.0 type T/C *(3),	0	Read / Write
Ch1_Function_H_C	1537	0: Heat: heating function 1: Cool: cooling function	0	Read / Write
Ch1_H_Hys	1538	0 ... 500 °C / 0.0.....50.0 °C *(3)	0	Read / Write
Ch1_Ct	1539	1 .. 200 seconds	4	Read / Write
Ch1_Pbc	1540	5 ... 150 °C	30	Read / Write
Ch1_ti	1541	0 ... 1800 seconds	300	Read / Write
Ch1_td	1542	0 ... 600 seconds	60	Read / Write
Ch1_OverShoot	1543	0: OFF, 1: 10.0, 2: 5.0, 3: 3.0, 4: 1.0, 5: 0.2	0	Read / Write
Ch1_Ramp_C_t	1544	0.0.....300.0 °C / minute *(5)	0	Read / Write
Ch1_SensorOffset	1545	0 ... 100 °C / 0.0.....100.0 °C *(3)	0	Read / Write
Ch1_P_Err	1546	0 ... 100 %	0	Read / Write
Ch1_C_dLY	1547	0 ... 300 seconds	15	Read / Write
Ch1_SET_2_InputSelect	1548	0: SET2 disabled 1: DIIn1 selects SET2 2: DIIn2 selects SET2	0	Read / Write
Reserved	1549	Do not write	0xFFFF	Read / Write
1550 - 1791; not defined				
Ch2_SensorType	1792	Same list as Ch1 *(1)	0	Read / Write
Ch2_Function_H_C	1793	Same list as Ch1 *(1)	0	Read / Write

Ch2_H_Hys	1794	Same list as Ch1 *(1)	0	Read / Write
Ch2_Ct	1795	Same list as Ch1 *(1)	4	Read / Write
Ch2_Pbc	1796	Same list as Ch1 *(1)	30	Read / Write
Ch2_ti	1797	Same list as Ch1 *(1)	300	Read / Write
Ch2_td	1798	Same list as Ch1 *(1)	60	Read / Write
Ch2_OverShoot	1799	Same list as Ch1 *(1)	0	Read / Write
Ch2_Ramp_C_t	1800	Same list as Ch1 *(1)	0	Read / Write
Ch2_SensorOffset	1801	Same list as Ch1 *(1)	0	Read / Write
Ch2_P_Err	1802	Same list as Ch1 *(1)	0	Read / Write
Ch2_C_dLY	1803	Same list as Ch1 *(1)	15	Read / Write
Ch2_SET_2_InputSelect	1804	Same list as Ch1 *(1)	0	Read / Write
Reserved	1805	Do not write	0xFFFF	Read / Write
1806 - 2047; not defined				
Ch3_SensorType	2048	Same list as Ch1 *(2)	0	Read / Write
Ch3_Function_H_C	2049	Same list as Ch1 *(2)	0	Read / Write
Ch3_H_Hys	2050	Same list as Ch1 *(2)	0	Read / Write
Ch3_Ct	2051	Same list as Ch1 *(2)	4	Read / Write
Ch3_Pbc	2052	Same list as Ch1 *(2)	30	Read / Write
Ch3_ti	2053	Same list as Ch1 *(2)	300	Read / Write
Ch3_td	2054	Same list as Ch1 *(2)	60	Read / Write
Ch3_OverShoot	2055	Same list as Ch1 *(2)	0	Read / Write
Ch3_Ramp_C_t	2056	Same list as Ch1 *(2)	0	Read / Write
Ch3_SensorOffset	2057	Same list as Ch1 *(2)	0	Read / Write
Ch3_P_Err	2058	Same list as Ch1 *(2)	0	Read / Write
Ch3_C_dLY	2059	Same list as Ch1 *(2)	15	Read / Write
Ch3_SET_2_InputSelect	2060	Same list as Ch1 *(2)	0	Read / Write
Reserved	2061	Do not write	0xFFFF	Read / Write
2062 - 2303; not defined				
Ch4_SensorType	2304	Same list as Ch1 *(2)	0	Read / Write
Ch4_Function_H_C	2305	Same list as Ch1 *(2)	0	Read / Write
Ch4_H_Hys	2306	Same list as Ch1 *(2)	0	Read / Write
Ch4_Ct	2307	Same list as Ch1 *(2)	4	Read / Write
Ch4_Pbc	2308	Same list as Ch1 *(2)	30	Read / Write
Ch4_ti	2309	Same list as Ch1 *(2)	300	Read / Write

Ch4_td	2310	Same list as Ch1 ^{*(2)}	60	Read / Write
Ch4_OverShoot	2311	Same list as Ch1 ^{*(2)}	0	Read / Write
Ch4_Ramp_C_t	2312	Same list as Ch1 ^{*(2)}	0	Read / Write
Ch4_SensorOffset	2313	Same list as Ch1 ^{*(2)}	0	Read / Write
Ch4_P_Err	2314	Same list as Ch1 ^{*(2)}	0	Read / Write
Ch4_C_dLY	2315	Same list as Ch1 ^{*(2)}	15	Read / Write
Ch4_SET_2_InputSelect	2316	Same list as Ch1 ^{*(2)}	0	Read / Write
Reserved	2317	Do not write	0xFFFF	Read / Write
2318 - 2559; not defined				
Ch1_AlrInputSelectIndex	2560	1: Ch1 Sensor Input 2: Ch2 Sensor Input ^{*(1)} 3: Ch3 Sensor Input ^{*(2)} 4: Ch4 Sensor Input ^{*(2)}	1	Read / Write
Ch1_AbsoluteAlarmSET	2561	-100.0.....1300.0 °C ^{*(3)} / -100.... 1300 °C	400	Read / Write
Ch1_AlarmHYS	2562	0.1.....50.0 °C ^{*(3)} / 1.....50 °C	3	Read / Write
Ch1_AlarmType	2563	0: Alarm_Abs, 1: Alarm_Rel, 2: Alarm_Bnd, 3: Alarm_Bni, 4: Alarm_m_Abs, 5: Alarm_m_Rel, 6: Alarm_m_Bnd, 7: Alarm_m_Bni, 8: Alarm_SNS_ON, 9: Alarm_SNS_FLS	1	Read / Write
Ch1_AlarmRelALR	2564	-100.0.....100.0 °C ^{*(3)} / -100.... 100 °C	3	Read / Write
Reserved	2565	Do not write	0xFFFF	Read / Write
2566 - 2815; not defined				
Ch2_AlrInputSelectIndex	2816	Same list as Ch1	1	Read / Write
Ch2_AbsoluteAlarmSET	2817	Same list as Ch1	400	Read / Write
Ch2_AlarmHYS	2818	Same list as Ch1	3	Read / Write
Ch2_AlarmType	2819	Same list as Ch1	1	Read / Write
Ch2_AlarmRelALR	2820	Same list as Ch1	3	Read / Write
Reserved	2821	Do not write	0xFFFF	Read / Write
2822 - 3071; not defined				

Ch3_AlrInputSelectIndex	3072	Same list as Ch1	1	Read / Write
Ch3_AbsoluteAlarmSET	3073	Same list as Ch1	400	Read / Write
Ch3_AlarmHYS	3074	Same list as Ch1	3	Read / Write
Ch3_AlarmType	3075	Same list as Ch1	1	Read / Write
Ch3_AlarmRelALR	3076	Same list as Ch1	3	Read / Write
Reserved	3077	Do not write	0xFFFF	Read / Write
3078 - 3327; not defined				
Ch4_AlrInputSelectIndex	3328	Same list as Ch1	1	Read / Write
Ch4_AbsoluteAlarmSET	3329	Same list as Ch1	400	Read / Write
Ch4_AlarmHYS	3330	Same list as Ch1	3	Read / Write
Ch4_AlarmType	3331	Same list as Ch1	1	Read / Write
Ch4_AlarmRelALR	3332	Same list as Ch1	3	Read / Write
Reserved	3333	Do not write	0xFFFF	Read / Write
3334 - 3583; not defined				
NetInData	3584	Refer to text	0	Read / Write
EnableRelaysData	3585	Refer to text	0x000F	Read / Write
EnableSSRsData	3586	Refer to text	0x000F	Read / Write
3587 - 3839; not defined				
StartAutoTune	3840	Write 0x0101 (decimal 257) to start auto-tune at Ch1 Write 0x0202 (decimal 514) to start auto-tune at Ch2 ^{*(1)} Write 0x0303 (decimal 771) to start auto-tune at Ch3 ^{*(2)} Write 0x0404 (decimal 1028) to start auto-tune at Ch4 ^{*(2)}	0	Reads 0
3841 - 4095; not defined				
CancelAutoTune	4096	Write 0x0101 (decimal 257) to cancel auto-tune at Ch1 Write 0x0202 (decimal 514) to cancel auto-tune at Ch2 ^{*(1)} Write 0x0303 (decimal 771) to cancel auto-tune at Ch3 ^{*(2)} Write 0x0404 (decimal 1028) to cancel auto-tune at Ch4 ^{*(2)}	0	Reads 0

* (1) These register accessible only for the devices having 2 or more sensor inputs.

* (2) These register accessible only for the devices having 3 or more sensor inputs.

* (3) If any sensor type ending with ".0" is selected then register content is x10; for example if SET is 102.5, then relevant register content is 1025.



*(4) These sensors are not defined for devices whose device codes end with 2T and 4T (only T/C input). Do not select these sensors for those devices.

*(5) The register content is always x10; for example, if the content is 1205 then its real value is 120.5 °C

Uint16: unsigned integer 16bits; 0 ... 65535

Sint16: signed integer 16bits; -32768 ... +32767

7. Document Updates Summary

Document Release No	Explanation
V 1.0	First release.
V 1.1	Some errors fixed at 4x table. Minor additions are done to the document for more clear understanding.
V1.2	"Supported Messages" section is added.
V1.3	Some errors fixed.