

GUIA RÁPIDA DE INSTALACIÓN
GUIDE RAPIDE D'INSTALLATION
QUICK INSTALLATION GUIDE



CONTROLADOR DE PROCESOS con WEB SERVER, BLUETOOTH y MQTT
 AFFICHEUR DE PROCESS avec WEB SERVER, BLUETOOTH et MQTT
 DPM for PROCESS CONTROL with WEB SERVER, BLUETOOTH and MQTT

The **MICRA-M/M6 MAX** incorporates Ethernet communication and configuration features:

- **Web Server:** Allows initial setup with login and provides instant readings of measured variables
- **BT Bluetooth :** After downloading the Ditel Connect application, the instrument can be configured via Smartphone.
Pairing : Push "ENTER" key to get "Pro", and BT key during 3 sec, display shows a 5 digit number during 2 minutes (*exemple : 47985*)
 The bluetooth library uses a 6-digit number to pair, so in our case we will have to add a 0 to the left (*exemple : 047985*)
- **MQTT Protocol:** Enables communication with an MQTT Server.
- **REST API :** Facilitates communication and data exchange between different systems. This includes:
 - MICRA-M MAX API (Specifications)
 - MICRA-M MAX API (Settings)
 - MICRA-M MAX API (PHP Functions)

For detailed information, visit the portal : micramax.ditel.es and download the User Manual (QR code)

Proceso. Process. Process.

Rango Plage Range	±20mA	±10V
Impedancia de entrada Impédance d'entrée Input impedance	15Ω	1MΩ
Precisión Précision Accuracy	±(0.1% rdg +1digit)	±(0.1% rdg +1 digit)
Excitación Excitation Excitation	24V @ 60mA	

Célula de carga. Pont de jauge. Strain gauge.

Rango Plage Range	±15 mV	±30 mV	±150 mV
Impedancia de entrada Impédance d'entrée Input impedance	100 MΩ		
Precisión Précision Accuracy	±(0.1% rdg + 1 digit)		
Excitación Excitation Excitation	10 V / 5 V @ 60 mA		

Potenciómetro. Potentiomètre. Potentiometer.

Rango Plage Range	Min 200 Ω Max 100 kΩ
Impedancia de entrada Impédance d'entrée Input impedance	1MΩ
Precisión Précision Accuracy	±0.1% rdg + 1 digit
Excitación Excitation Excitation	10 V DC

Temperatura. Température. Temperature.

RTD (IEC 60751)	Pt100 (°C)	Pt100 (°F)
Rango Plage Range	-200°C +800°C	-328°F +1472°C
Máxima corriente de medida Courant maximale de mesure Maximum measurement current	1mA	
Máxima resistencia por hilo Résistance maximale par fil Maximum resistance per wire	40Ω	
Coefficiente Coefficient Coefficient	α = 0.00385	
Precisión Précision Accuracy	±(0.2% rdg + 0.6°C) ±(0.2% rdg + 1°F)	

TC (IEC 60584-1)	J	K	T	N
Rango Plage Range	-150°C/ +1100°C -238°F +2012°F	-150°C +1200°C -238°F +2192°F	-200°C +400°C -328°F +752°F	-150°C +1300°C -238°F +2372°F
Compensación unión fría Compensation jonction froide Cold junction compensation	-10°C / +60°C ±(0.05°C/°C + 0.1°C)			
Precisión Précision Accuracy	0.4%rdg±0.6°C (res 0.1°) 0.4%rdg±1°F (res 0.1°) 0.4%rdg±1°C (res 1°) 0.4%rdg±2°F (res 1°)			

Conformidad CE. Conformité CE. CE Conformity.

Directivas Directives Directives	EMC 2014/30/UE	LVD 2014/35/UE
Normas Normes Standards	EN 61000-6-2 EN 61000-6-3	EN 61010-1



Para una información más completa, por favor consulte el manual de instrucciones en nuestra web
 Pour plus d'informations veuillez consulter le manuel dans notre site web
 For complete instructions please refer to the user manual in our website

DOWNLOAD
USER MANUAL



Según la Directiva 2012/19/UE, no puede deshacerse de este aparato como un residuo urbano normal. Puede devolverlo, sin coste alguno, al lugar donde fue adquirido para que de esta forma se proceda a su tratamiento y reciclado controlados.
 Selon la Directive 2012/19/UE, l'utilisateur ne peut se défaire de cet appareil comme d'un residu urbain courant. Vous pouvez le restituer, sans aucun coût, au lieu où il a été acquis afin qu'il soit procédé à son traitement et recyclage contrôlés.
 According to 2012/19/EU Directive, You cannot dispose of it at the end of its lifetime as unsorted municipal waste. You can give it back, without any cost, to the place where it was acquired to proceed to its controlled treatment and recycling.

DIAGRAMAS DE CONFIGURACIÓN

SCHÉMAS DE CONFIGURATION

SEÑAL DE ENTRADA

SIGNAL D'ENTRÉE

INPUT SIGNAL

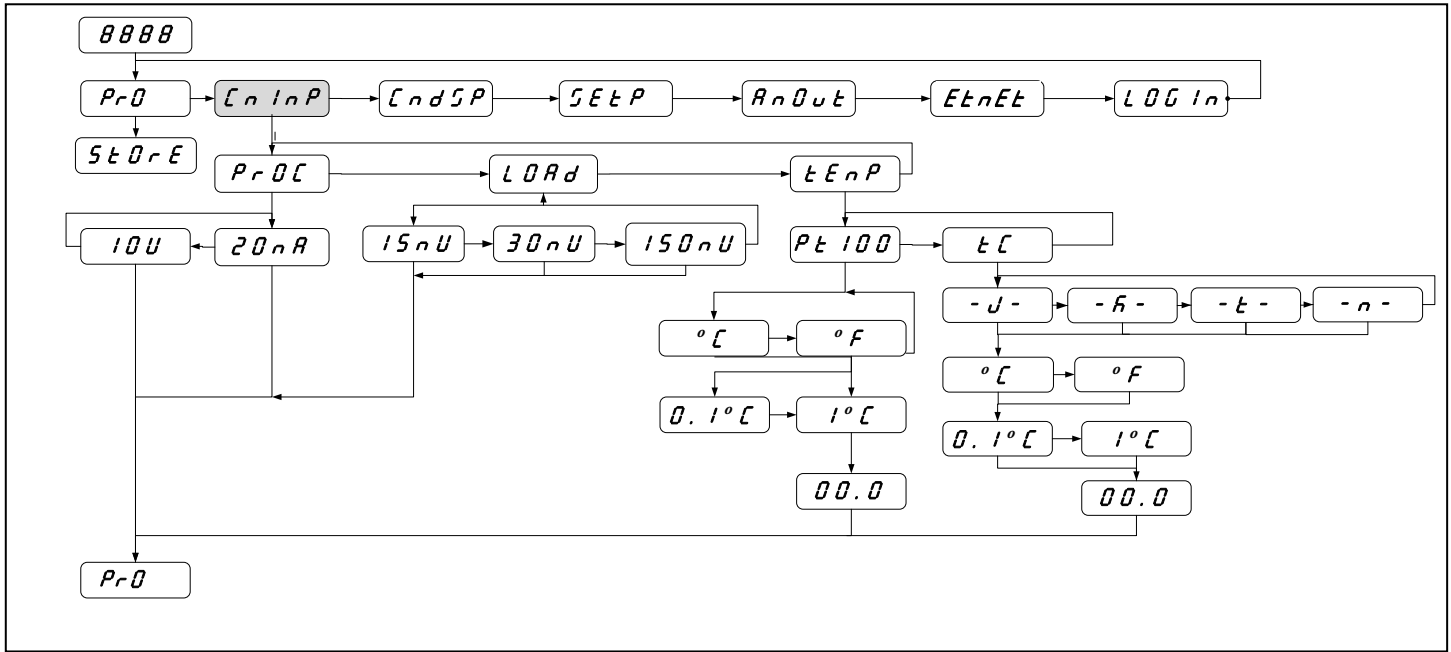

ENTRADAS DIGITALES ENTRÉES LOGIQUES

DIGITAL INPUTS

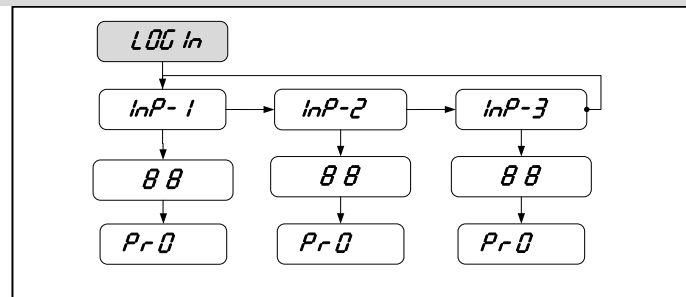

BLOQUEO VERROUILLAGE

LOCKING

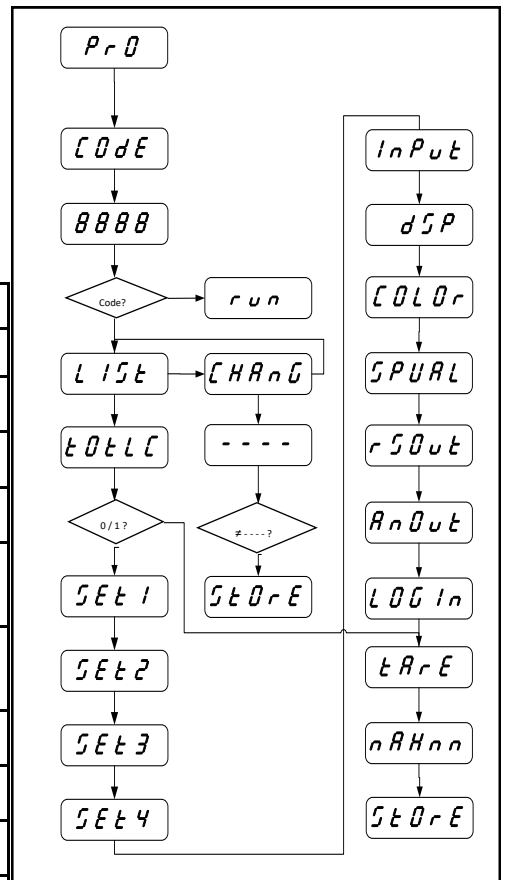

Nº	Function	Description	Activation by
0	Deactivated	None	None
1	TARE *	Adds the current display value to the tare memory and sets the display to zero.	Falling edge
2	TARE RESET *	Adds the tare memory to the display value and clears the tare memory.	Falling edge
3	LIST RESET	Performs a reset of the peak or the valley, depending on selection.	Falling edge
4	SEE LIST	Displays peak value (MAX.), valley value (MIN.), tare value (TARE) or gross value (GROSS) depending on selection.	Low level
5	PRINT LIST	Sends to the printer depending on selection MAX., MIN, TARE, SET1, SET2, SET3 or SET4 value.	Falling edge
6	HOLD	Freezes the display while all the outputs remain active	Low level
7	BRIGHTNESS	Changes the display brightness from Hi to Low	Low level
8	DISPLAY COLOR	Changes display color (green, red or amber)	Low level
9	SETP PROG/TARE	Configures Setpoints or Tare depending on Selection List (TARE, SET1, SET2, SET3 and SET4)	Falling edge
10	FALSE SETPOINTS	Simulates that the instrument has a four Setpoints option installed	Low level
11	KEYBOARD EMULATION	Emulates keyboard (Input 1=ENTER, Input 2=SHIFT, Input 3=UP)	Low level
12	RESERVED		

- 0** : Desbloqueado / Déverrouillé
Unlocked
- 1** : Bloqueado / Verrouillé
Locked

* Only with mode TARE 1 and TARE 3

CONFIGURATION DIAGRAMS

DISPLAY

AFFICHAGE

DISPLAY

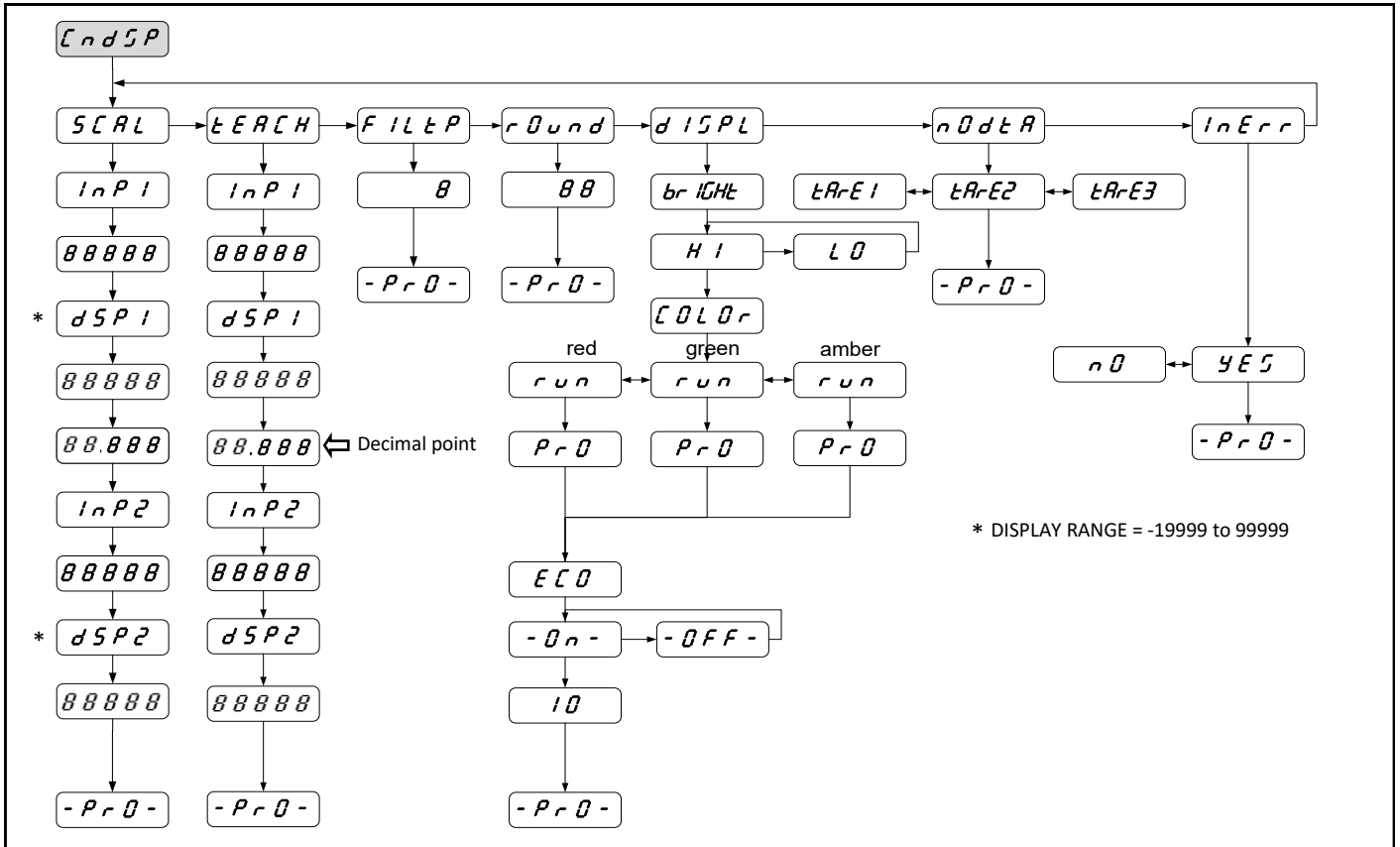

RELÉS

RELAIS

RELAYS

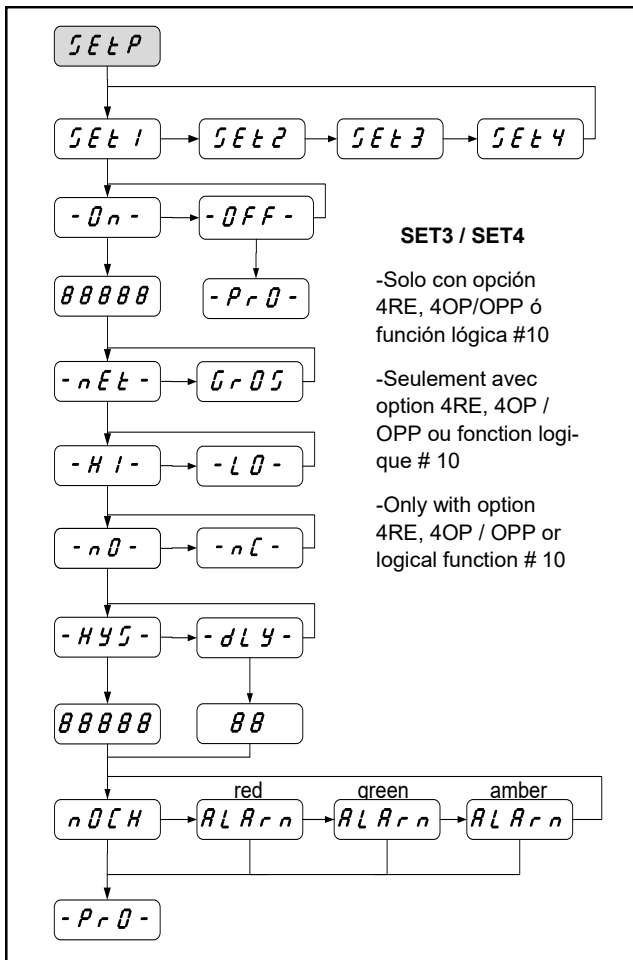

SALIDA ANALÓGICA

SORTIE ANALOGIQUE

ANALOG OUTPUT

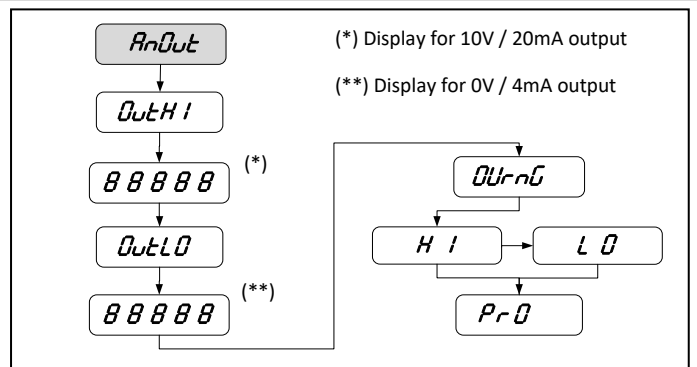

SALIDA RS2/RS4

SORTIE RS2/RS4

RS2/RS4 OUTPUT

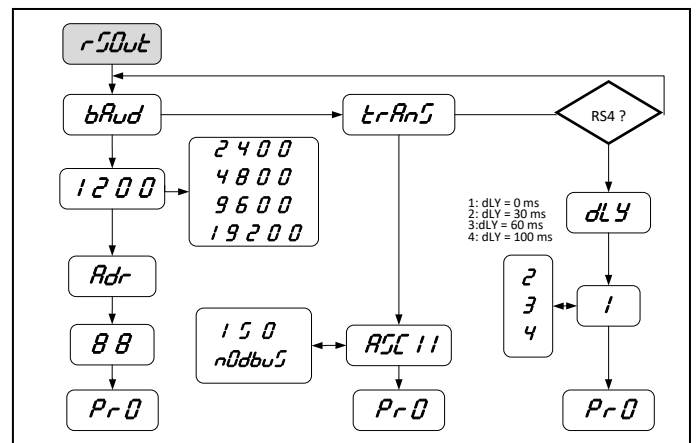

CONEXIONADO

RACCORDEMENT

CONNECTIONS

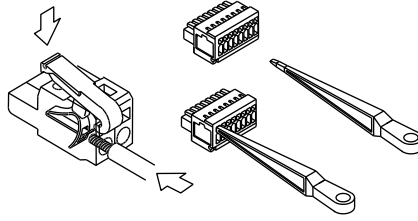
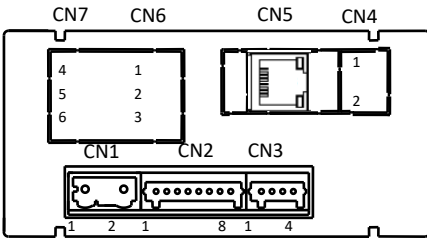

WIRING and POWER SUPPLY RANGE

MICRA-M MAX

85 V – 265 V AC 50/ 60 Hz to 100 – 300 V DC

MICRA-M6 MAX

22 – 53 V AC 50/ 60 Hz to 10,5 - 70 V DC

PIN 1: Phase / VDC PIN 2: Neutral / VDC

Recommended fuse : MICRA-M MAX (0.5A)
MICRA-M6 MAX (2A)

NOTE: When DC power supply polarity in connector CN1 is indistinct.

CN2 INPUT SIGNAL PROCES

PIN 1 = -EXC	[excitation output (-)]
PIN 2 = +EXC	[excitation output +24V (+)]
PIN 3 = +EXC	[excitation output +5V or 10V (+)]
PIN 4 = N/C	[no connection]
PIN 5 = +IN	[input mA (+)]
PIN 6 = +IN	[input V (+)]
PIN 7 = N/C	[no connection]
PIN 8 = -IN	[input V (-), mA(-)]

CN2 INPUT SIGNAL STRAIN GAUGE

PIN 1 = -EXC	[excitation output (-)]
PIN 2 = N/C	[no connection]
PIN 3 = +EXC	[excitation output +5V or 10V (+)]
PIN 4 = N/C	[no connection]
PIN 5 = N/C	[no connection]
PIN 6 = N/C	[no connection]
PIN 7 = +IN	[input mV (+)]
PIN 8 = -IN	[input mV (-)]

CN2 INPUT SIGNAL TEMPERATURE

PIN 1 = N/C	[no connection]
PIN 2 = N/C	[no connection]
PIN 3 = N/C	[no connection]
PIN 4 = Pt100 Common	
PIN 5 = N/C	[no connection]
PIN 6 = N/C	[no connection]
PIN 7 = Pt100 / +TC	
PIN 8 = Pt100 / -TC	

CN3 DIGITAL INPUTS (Factory Configuration)

PIN (INPUT)	Function	Number
PIN 1	COMMON	
PIN 2 (INP-1)	TARE	Function nº 1
PIN 3 (INP-2)	RESET TARE	Function nº 2
PIN 4 (INP-3)	HOLD	Function nº 6

CN4 ANALOG OUTPUT

4-20mA (OPTION)	0-10V (OPTION)
PIN 1 = (-) [4-20 mA]	PIN 1 = (-) [0-10V]
PIN 2 = (+) [4-20 mA]	PIN 2 = (+) [0-10V]

CN6 / CN7 RELAIS OUTPUT OPTION

2RE	4RE	40P/40PP
PIN 1 = NO1	PIN 1 = RL1	PIN 1 = OPTO1
PIN 2 = COMM1	PIN 2 = RL2	PIN 2 = OPTO2
PIN 3 = NC1	PIN 3 = RL3	PIN 3 = OPTO3
PIN 4 = NO2	PIN 4 = RL4	PIN 4 = OPTO4
PIN 5 = COMM2	PIN 5 = N/C	PIN 5 = N/C
PIN 6 = NC2	PIN 6 = COMMON	PIN 6 = COMMON

ETHERNET OUTPUT

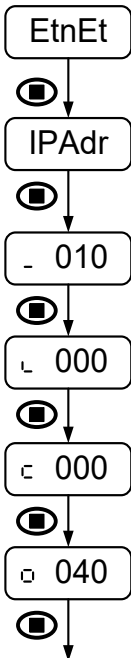

CN5 RJ45

PIN 1 = +Tx	PIN 5 = N.C.
PIN 2 = - Tx	PIN 6 = - RX
PIN 3 = +Rx	PIN 7 = N.C.
PIN 4 = N.C.	PIN 8 = N.C.

IP ADDRESS

Example :
10.0.0.40

For detailed information, visit the portal :
micramax.ditel.es and
download the User Manual (QR code)



Fusible Relé recomendado :
Fusible Relais recommandé : (2RE = 8A / 4RE = 5A)
Recommended Relais fuse :

Dimensiones y montaje Dimensions et montage Dimensions and mounting

Estanqueidad frontal
Étanchéité du frontal
Frontal protection degree

IP65

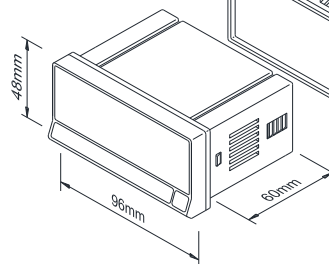

Orificio en panel
Orifice dans le panneau
Panel cutout:
92 x 45 mm